

# PRODUCT SHEET

## Twist security seal

### ES 110

<b>Type of seal</b>	twist	
<b>Security level</b>	indicative	
<b>Seal body material</b>	PC - polycarbonate	
<b>Sealing wire material</b>	plastic coated steel	
<b>Wire tension strength</b>	400 N (40 kg)	
<b>Operating temperature</b>	-40°C to +100°C	
<b>Wire diameter</b>	0,96 mm	
<b>Wire length</b>	400 mm	
<b>Min. diameter of application hole</b>	1,2 mm	
<b>Method of application</b>	manual, no tools needed	
<b>Method of removal</b>	simple cutting tool	
<b>Technology of marking</b>	laser engraving	
<b>Marking</b>	Text	YES
	Logo	YES
	Numbering	consecutive, 8 digits on the flag
	Bar code	YES
<b>Colors</b>	yellow, red, blue	
<b>Packing</b>	1 000 pcs in carton, carton weight 4,20 kg	
<b>Use</b>	Sealing of circuit breakers, electricity meters, power grids, shipping boxes, various closures, checkpoints, bolts, flanges, valves, marking of hand tools etc.	

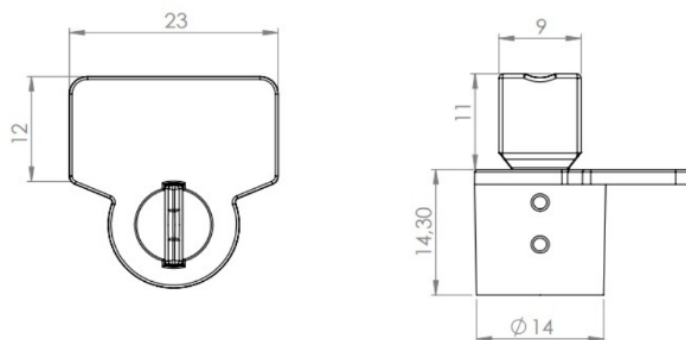

Dimensions are given in mm